

General and specific objectives

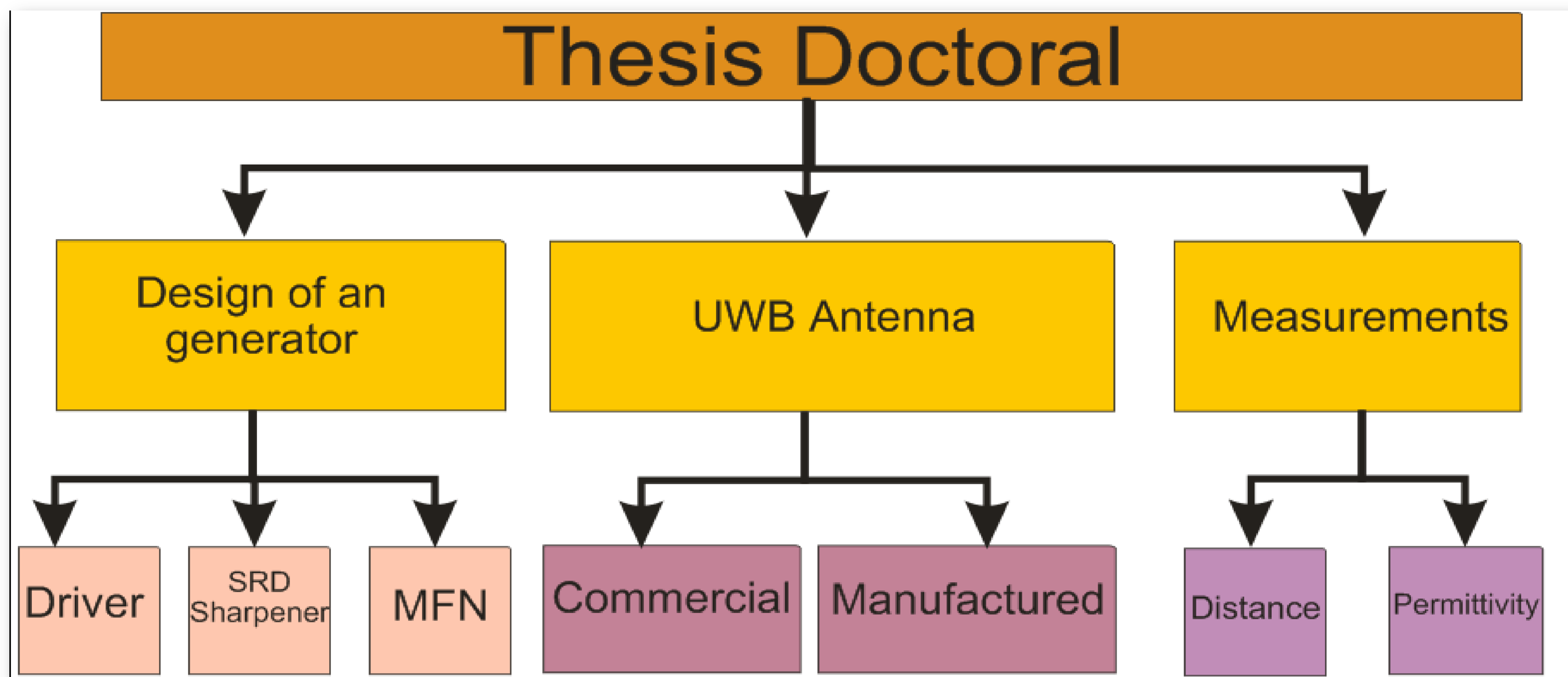

programming Thesis's map

main phases of development of research

Design of an Generator

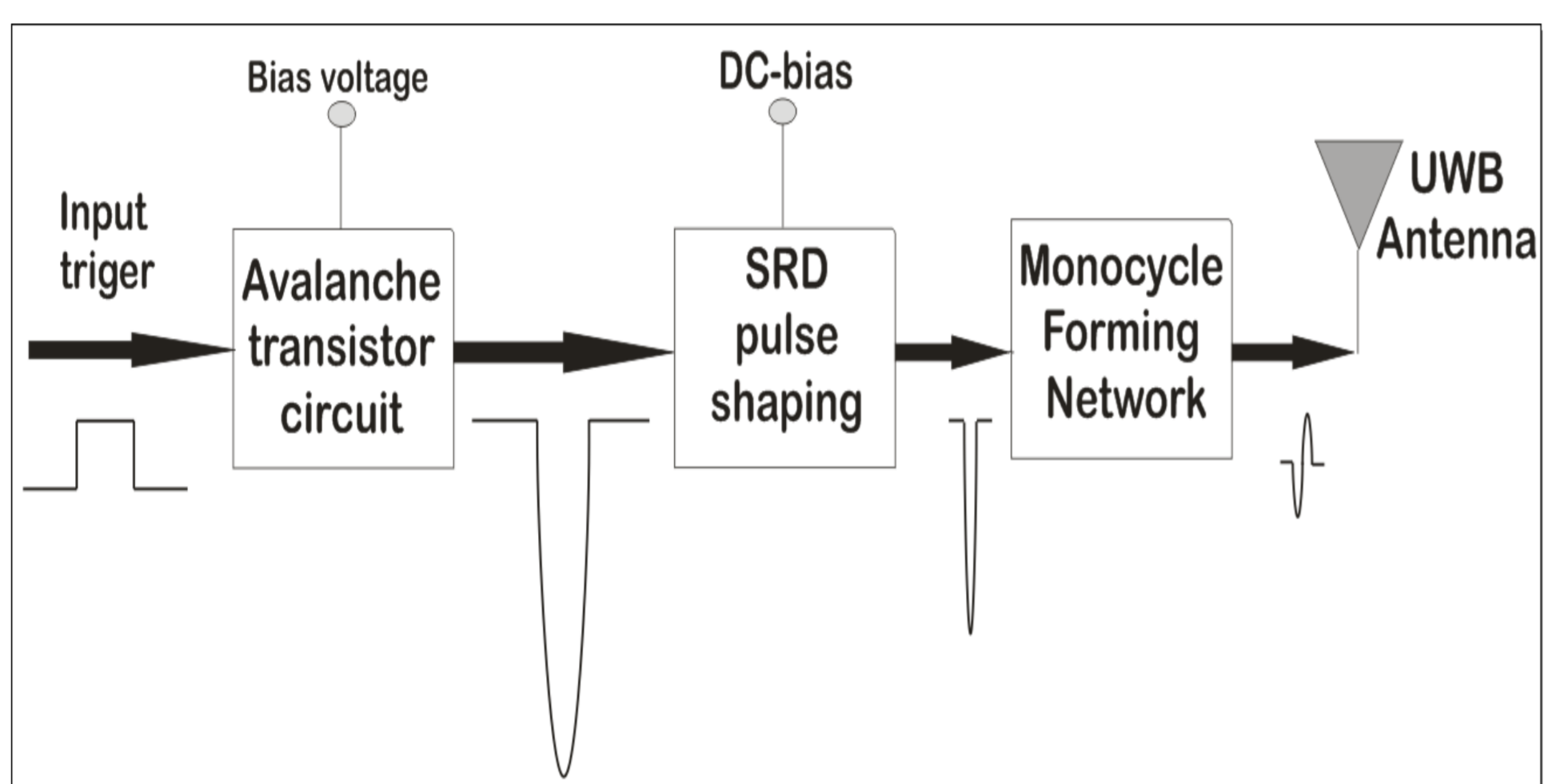

Designed Circuit Propose

UWB Antenna

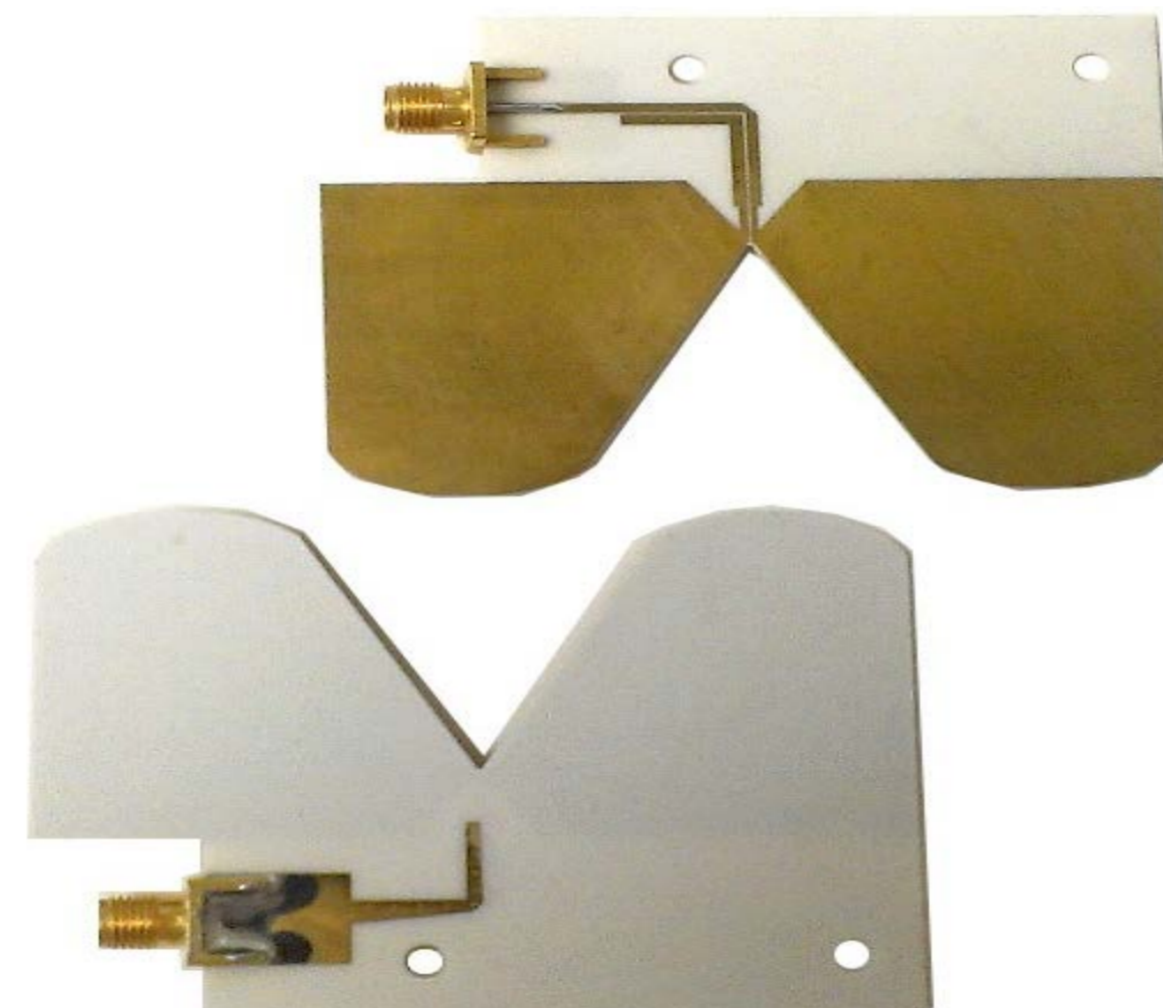

Bow-tie antenna

Measurements



Measurement in Anechoic chamber

Expected results

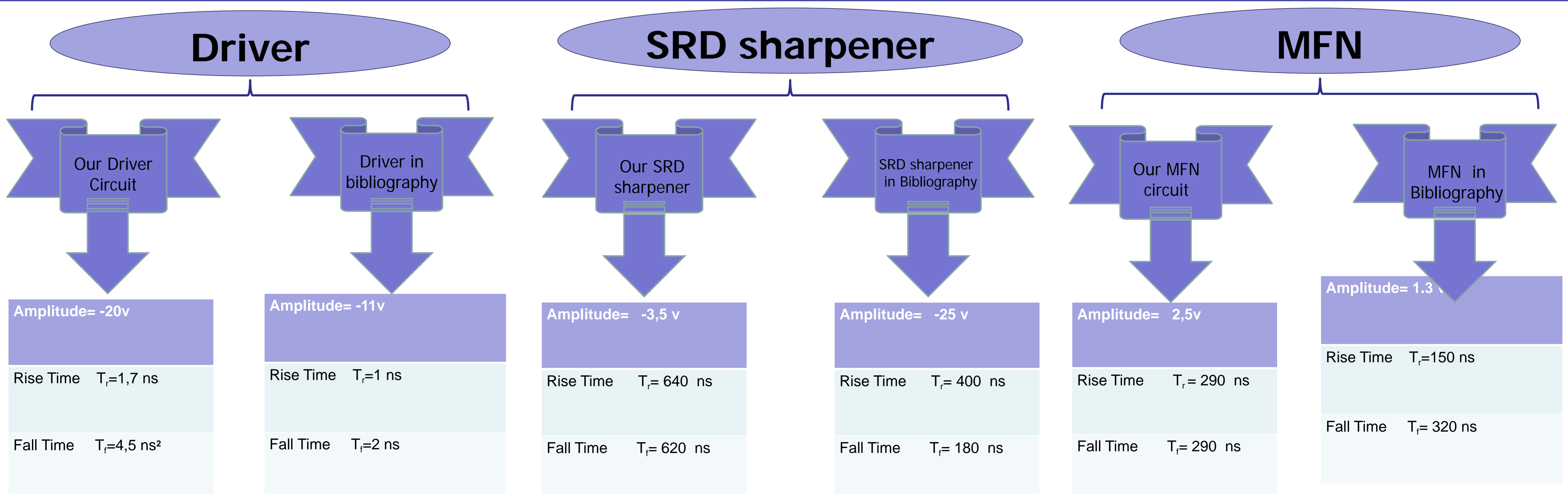

possible uses

